

# 차세대 전자-이온 충돌기 T1C로 보는 물질의 근원: 양성자의 질량과 스핀은 어디서 오는가?

고에너지물리학회

김준영  
인하대학교



# 물질이란 무엇인가?

**물질(Matter):** 질량과 부피를 가지며, 우리 주변의 모든 물체를 구성하는 존재



Wine from Germany /  
Lidl / €6

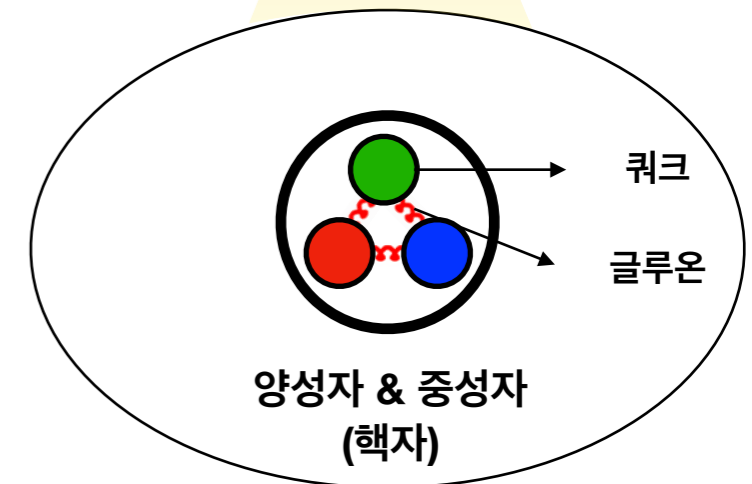
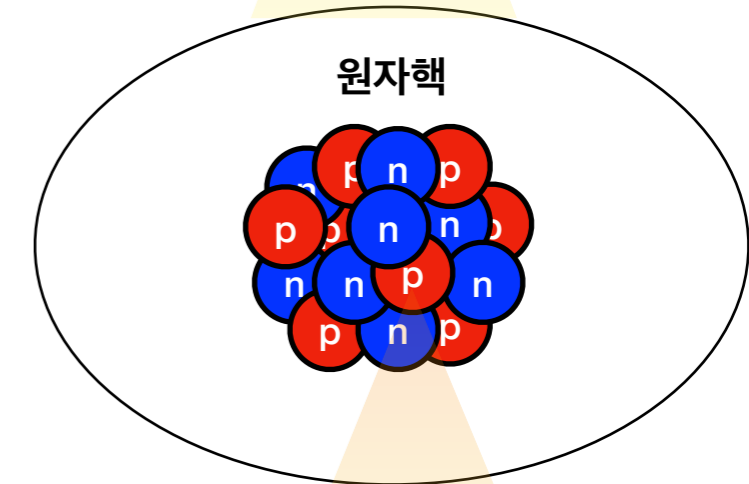
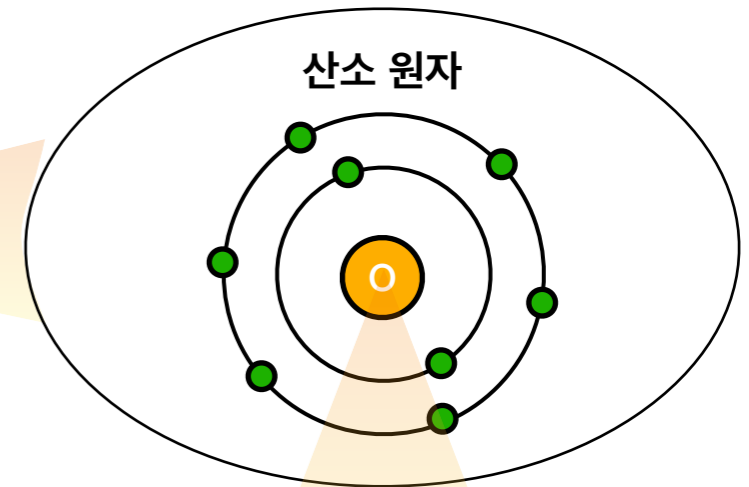
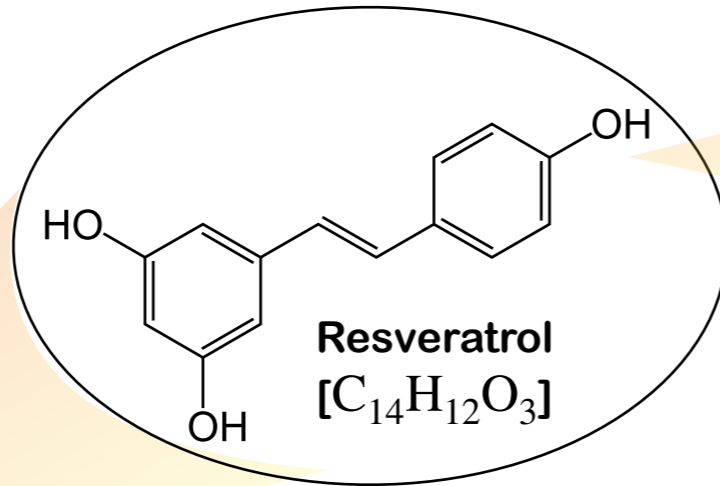

**핵물리학**

저에너지

중간/고에너지

**강입자물리**

질량의 근원은 무엇인가?

# 양성자

양성자는 20세기 초 어니스트 러더퍼드(Ernest Rutherford)가 발견했지만, 100년이 지난 지금도 내부 구조와 동역학은 여전히 미해결 문제로 남아 있다.

[The Cardiff Meeting of the British Association. Nature (1920)]

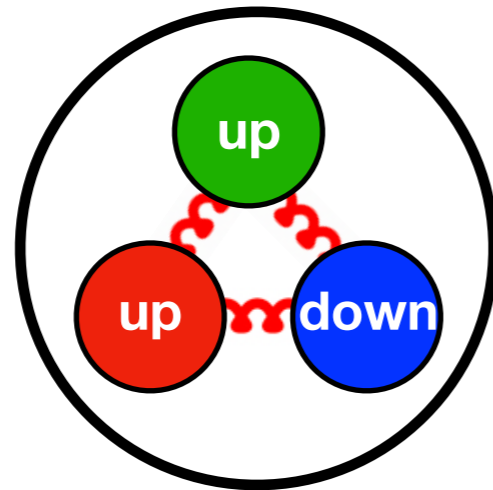

[양성자]

- 질량:  $938 \text{ MeV}/c^2 \approx 1.67 \times 10^{-27} \text{ kg}$
- 스핀:  $1/2$
- 구성: 세 개의 쿼크

쿼크로 양성자의 질량과 스핀을 설명할 수 있을까?

# 양성자 질량의 근원

## Mass without mass



쿼크 질량의 합  $\ll$  양성자의 질량

$$1.62 \times 10^{-29} \text{ kg} \ll 1.67 \times 10^{-27} \text{ kg}$$

양성자 질량의 단 1% 수준 만 설명 가능

# 양성자 스핀의 근원

## Proton spin crisis

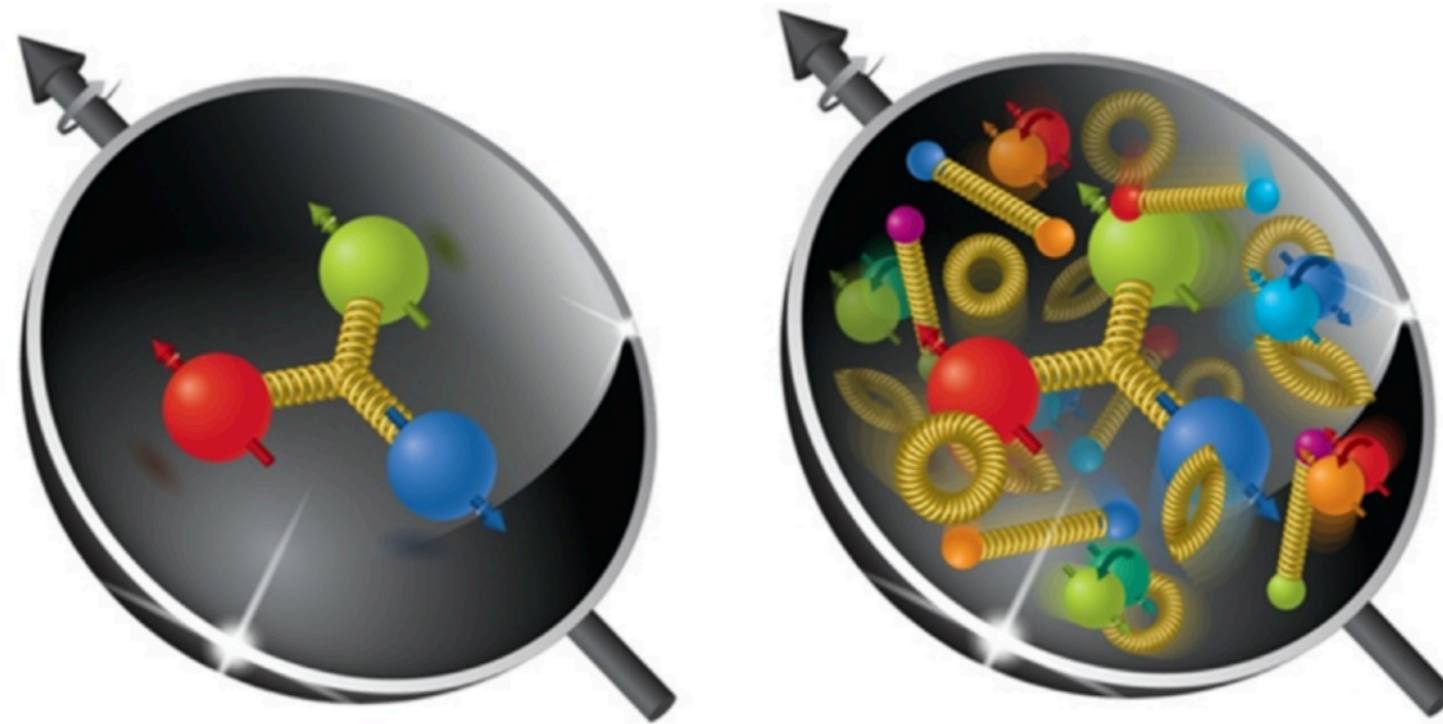

측정된 쿼크 스핀의 합  $\ll$  양성자의 스핀

0.1  $\ll$  0.5

양성자 스핀의 대략 20% 만 설명 가능

# Electron-Ion Collider (EIC) in the U.S.

Approve Start of  
Operations: 2036

[FY 2026 Congressional Justification]

| Fiscal Year | CD-0     | Conceptual Design Complete | CD-1      | CD-2       | Final Design Complete | CD-3       | CD-4       |
|-------------|----------|----------------------------|-----------|------------|-----------------------|------------|------------|
| FY 2026     | 12/19/19 | 01/12/21                   | 6/29/2021 | 2Q FY 2026 | 3Q FY 2025            | 2Q FY 2027 | 1Q FY 2036 |

Cost: 1.7–2.6 billion dollars / 약 2–4조 원

↓  
Current status: CD-3B approved;  
long-lead procurements underway

20-SC-52 Electron Ion Collider (EIC), BNL  
Brookhaven National Laboratory, BNL  
Project is for Design and Construction

## 1. Summary, Significant Changes, and Schedule and Cost History

### Summary

The EIC project will acquire facilities, infrastructure, systems, and equipment that will enable scientists to investigate the basic building blocks of nuclei and how quarks and gluons, the particles inside neutrons and protons, interact dynamically via the strong force to generate the fundamental properties of neutrons and protons, such as mass and spin. The FY 2026 Request for the EIC is \$110,000,000 of TEC funding and \$2,850,000 of OPC funding. The current TPC range is \$1,700,000,000 to \$2,800,000,000. The Critical Decision (CD)-1, Approve Alternative Selection and Cost Range, attained on June 29, 2021, included a TPC range with an upper bound of \$2,800,000,000.

[U.S. Department of Energy (DOE)]

# Electron-Ion Collider in the U.S.

## SCIENCE REQUIREMENTS AND DETECTOR CONCEPTS FOR THE ELECTRON-ION COLLIDER

EIC Yellow Report



arXiv:2103.05419v3 [physics.ins-det] 27 Oct 2021

## Contents

|   |            |
|---|------------|
| Title Page  | <b>i</b>   |
| Author List   | <b>iii</b> |
| Abstract  | <b>ix</b>  |
| Table of Contents   | <b>xi</b>  |
| <b>Volume I: Executive Summary</b>                                    | <b>1</b>   |
| <b>1 The Electron-Ion Collider</b>                                    | <b>3</b>   |
| <b>2 Physics Measurements and Requirements</b>                        | <b>6</b>   |
| 2.1 Introduction . . . . .  | <b>6</b>   |
| 2.2 Origin of Nucleon Spin . . . . .                                  | <b>9</b>   |
| 2.3 Origin of Nucleon Mass . . . . .                                  | <b>10</b>  |
| 2.4 Multi-Dimensional Imaging of the Nucleon . . . . .                | <b>11</b>  |
| 2.5 Imaging the Transverse Spatial Distributions of Partons . . . . . | <b>12</b>  |
| 2.6 Physics with High-Energy Nuclear Beams at the EIC . . . . .       | <b>13</b>  |
| 2.7 Nuclear Modifications of Parton Distribution Functions . . . . .  | <b>14</b>  |
| 2.8 Passage of Color Charge Through Cold QCD Matter . . . . .         | <b>15</b>  |
| 2.9 Connections to Other Fields . . . . .                             | <b>17</b>  |
| 2.10 Summary of Machine Design Parameters . . . . .                   | <b>18</b>  |

# Electron-Ion Collider in the U.S.

EIC 목표: 전자 산란으로 핵자의 내부 구조를 밝힌다.

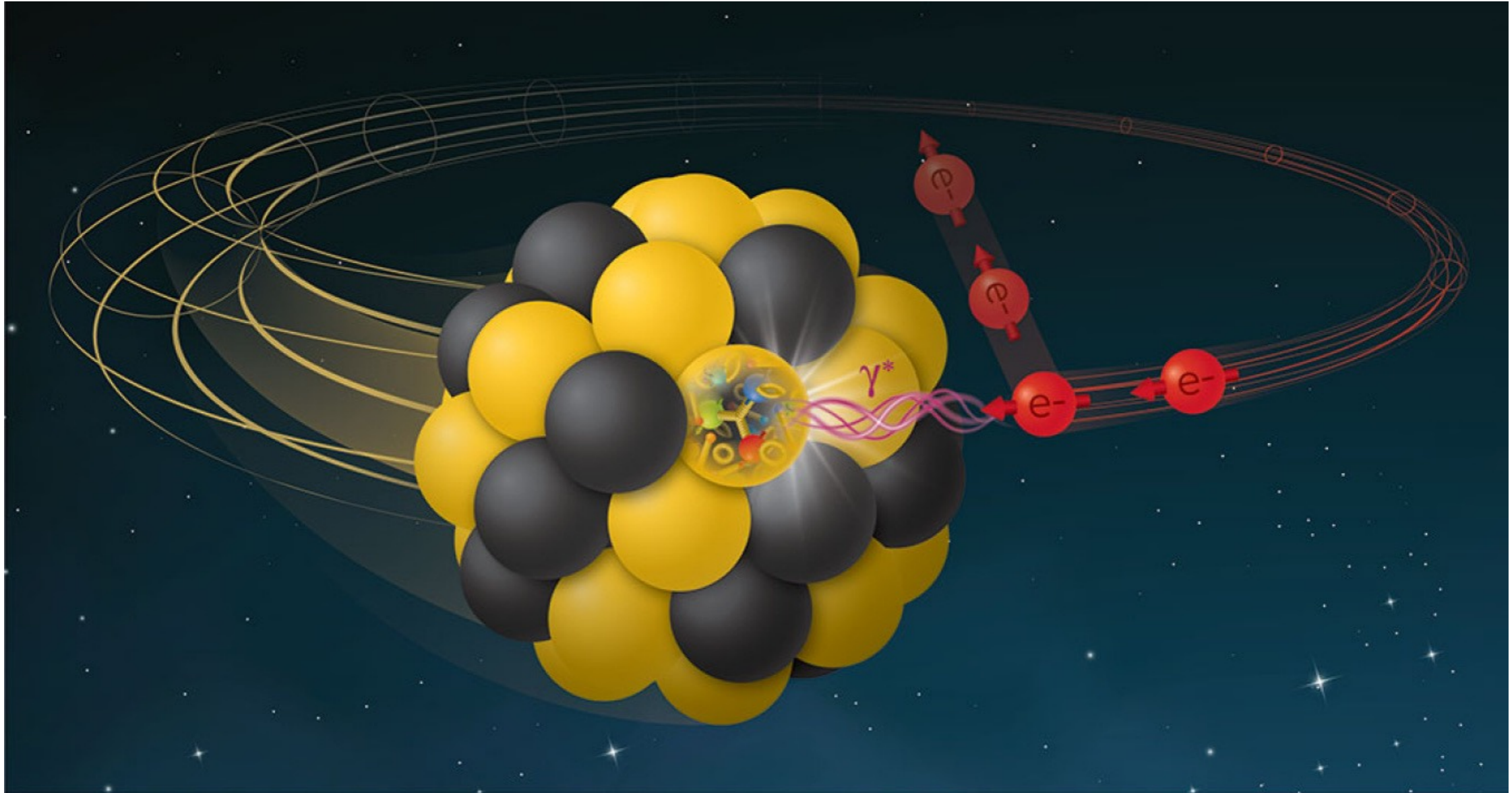

**일반화된 파톤 분포함수(GPD)**는 핵자의 3차원 구조 정보를 담고 있다.

→ GPD에서 질량과 스핀 정보를 담은 에너지-운동량 텐서를 얻는다.

# 3차원 토모그래피

## Generalized parton distributions

### Deeply Virtual Compton Scattering

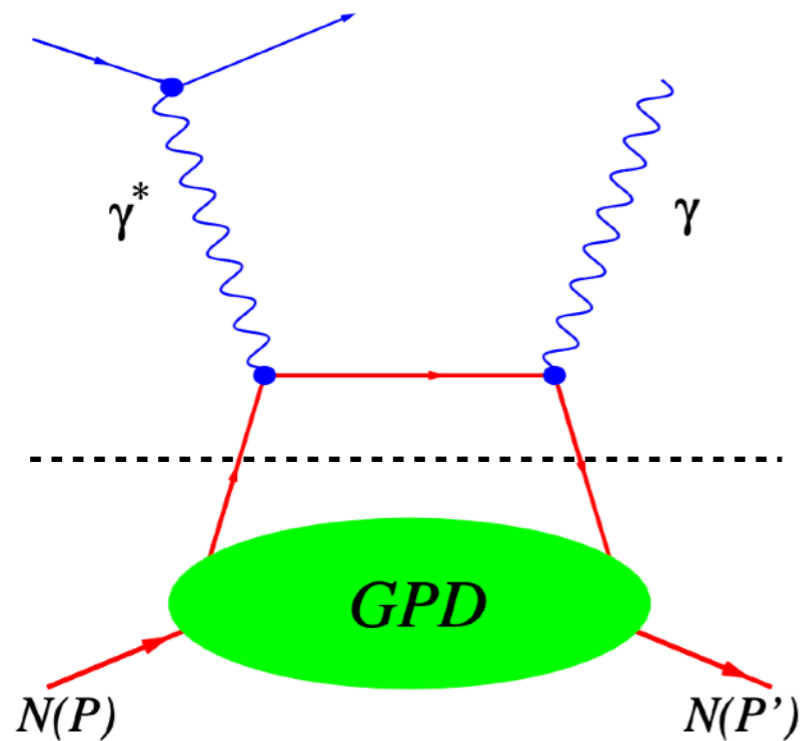

→  
3D Tomography

비섭동 양자색역학 지배 영역

$$GPD = \int \frac{d\lambda}{2\pi} e^{i\lambda x} \langle N | \bar{\psi}(-\lambda n/2) \gamma^\mu n_\mu \psi(\lambda n/2) | N \rangle$$

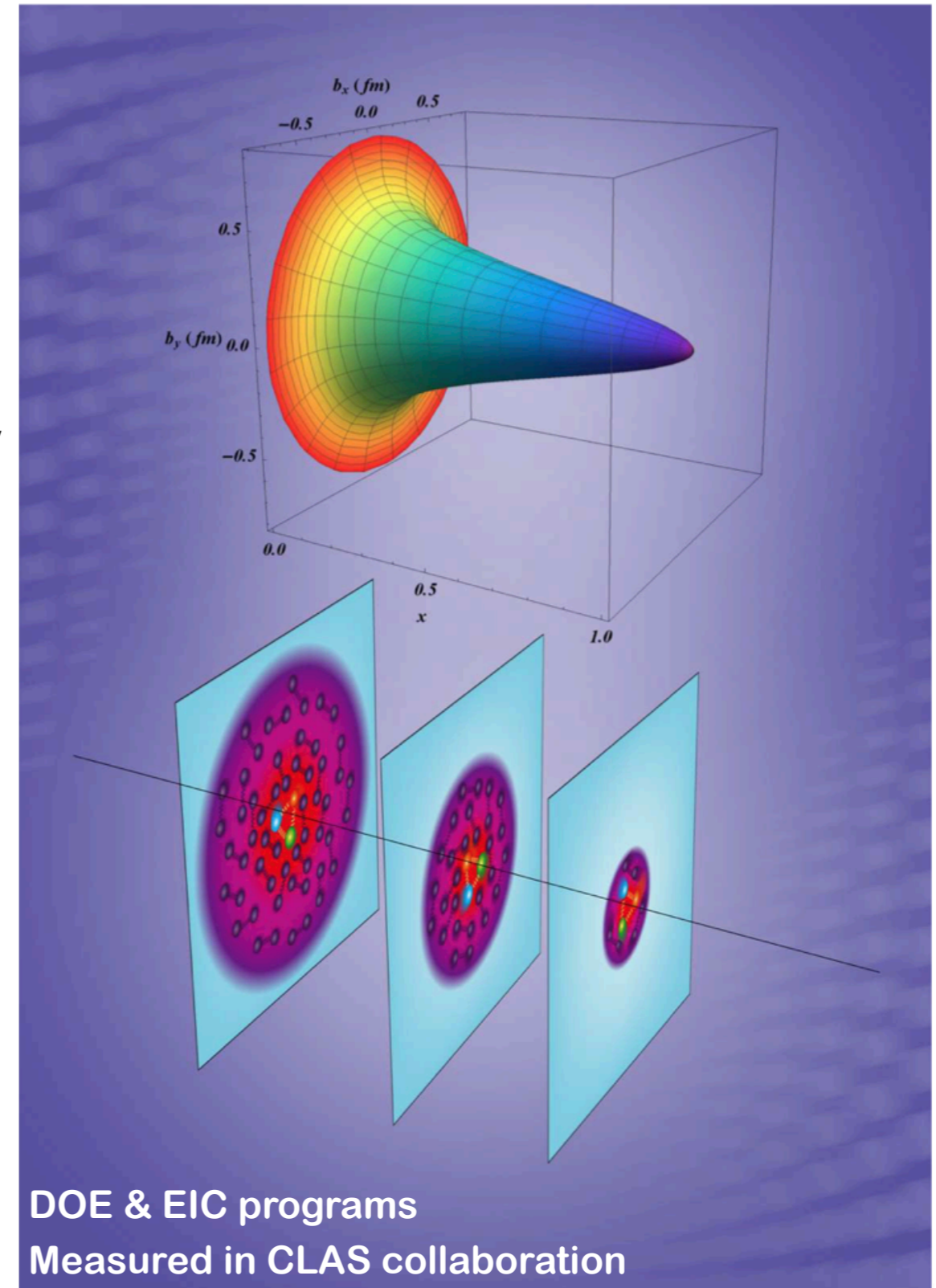

# 에너지-운동량 텐서 (EMT)

## Deeply Virtual Compton Scattering

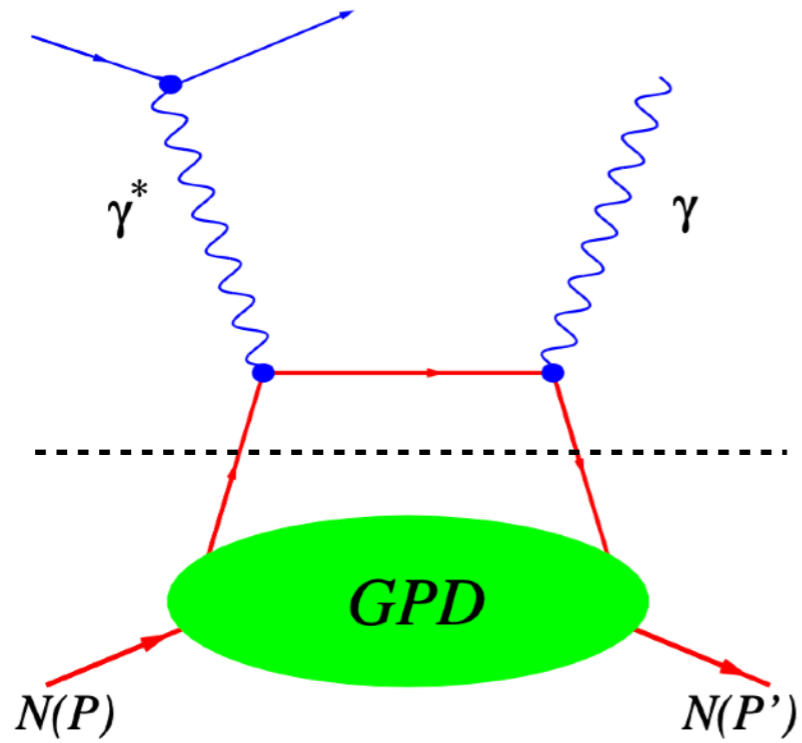

## Energy-moment tensor

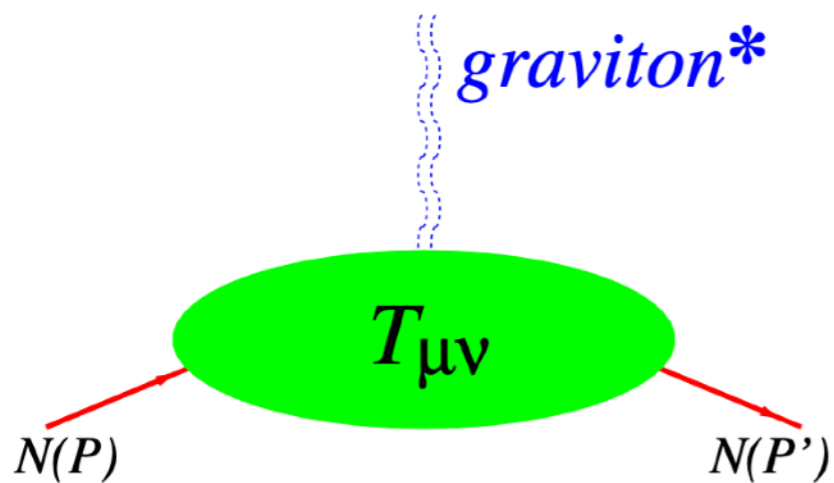

$$\text{GPD} = \int \frac{d\lambda}{2\pi} e^{i\lambda x} \langle N | \bar{\psi}(-\lambda n/2) \gamma^\mu n_\mu \psi(\lambda n/2) | N \rangle$$



Moment

$$n_\mu n_\nu \langle N | \hat{T}_q^{\mu\nu} | N \rangle = n_\mu n_\nu \langle N | \bar{\psi}(0) D^\nu \gamma^\mu \psi(0) | N \rangle$$

에너지-운동량 텐서

쿼크와 글루온의 기여를 각각 볼 수 있다.

$$\hat{T}^{\mu\nu} = \hat{T}_q^{\mu\nu} + \hat{T}_g^{\mu\nu}$$

# 양성자의 에너지-운동량 텐서

[EIC 핵심 관측량: **중력 형태 인자**]

$$\langle N | \hat{T}_{\mu\nu} | N \rangle = \bar{u} \left[ A(t) \frac{P_\mu P_\nu}{M_N} + J(t) \frac{iP_{\{\mu\sigma\nu\}\rho} \Delta^\rho}{2M_N} + D(t) \frac{\Delta_\mu \Delta_\nu - g_{\mu\nu} \Delta^2}{4M_N} + \bar{c}(t) M_N g_{\mu\nu} \right] u,$$

분해:

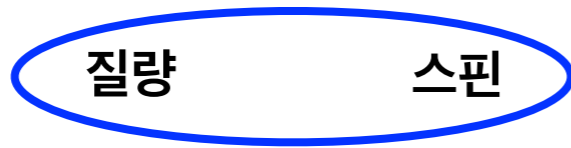

[이론 예측들]

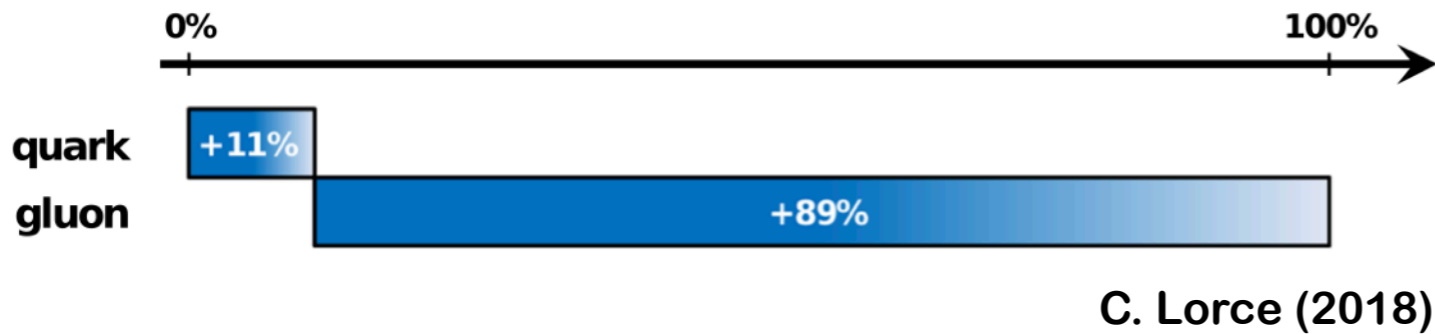

- 향후 **EIC**에서 측정해야 할 주요 관측량
- **비섭동 글루온**의 역할을 이해하는 것이 중요
- 2036년까지 다양한 이론적 연구(서포트)가 필요

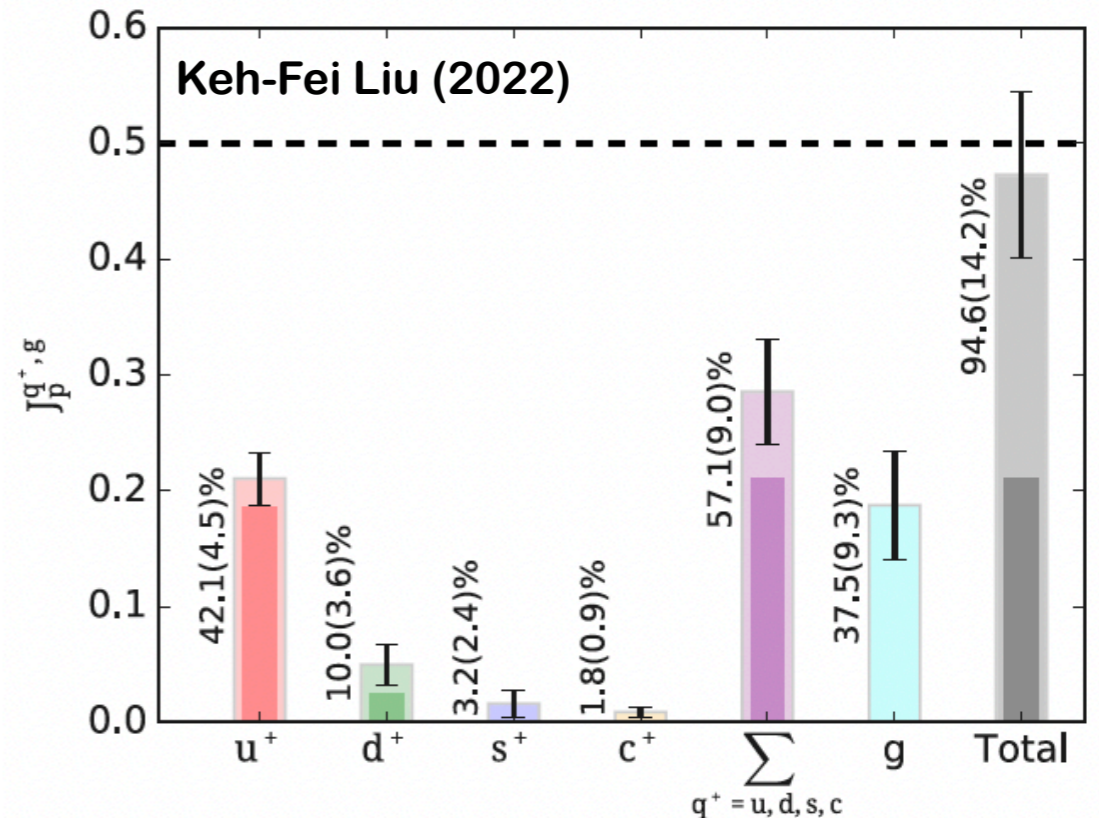

**EIC가 밝히는 QCD 동역학의 열쇠:**

**비섭동 글루온**

# 양자색역학 (Quantum ChromoDynamics)

QCD는 글루온이 매개하는 쿼크 사이의 강한 상호작용을 설명하는 기초 이론이다.

## QCD 라그랑지안

$$\mathcal{L}_{\text{QCD}} = \sum_f \underbrace{\bar{\psi}_f \left[ i\gamma_\mu D^\mu - m_f \right] \psi_f}_{\text{쿼크}} - \underbrace{\frac{1}{4} F_{\mu\nu}^a F^{a\mu\nu}}_{\text{글루온}}$$

쿼크는 QCD 진공의 비섭동 글루온 장 요동과 상호작용하여 동역학적 질량을 얻는다.

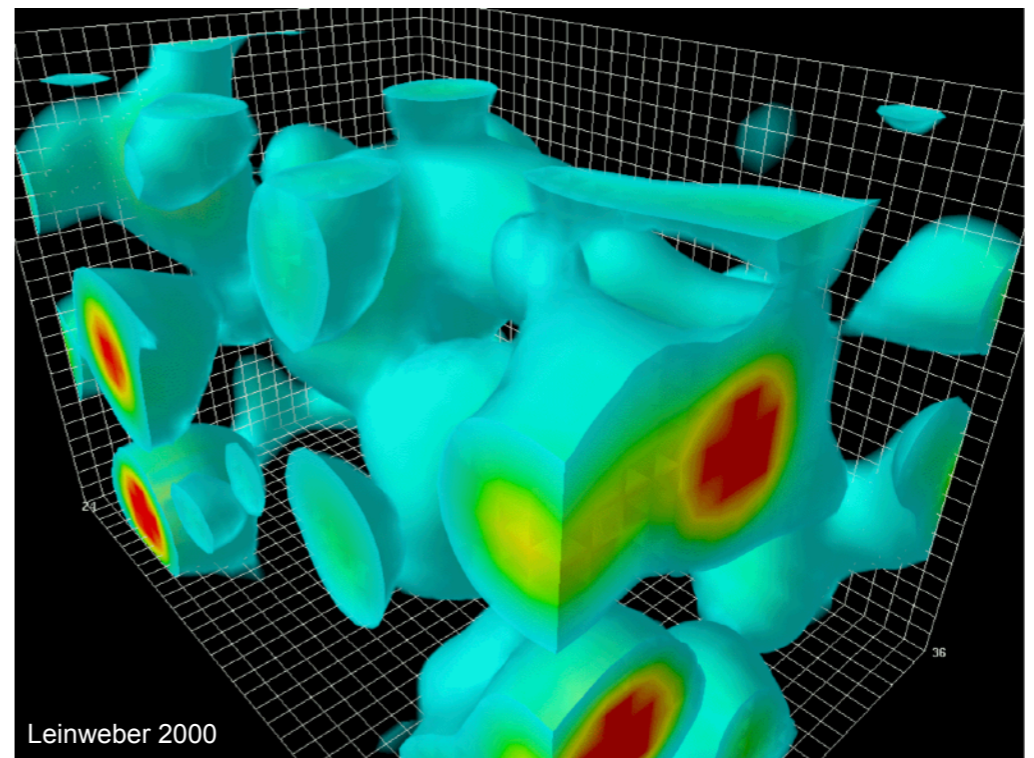

Leinweber 2000

[QCD 진공]

# QCD 인스턴톤 진공: 모델링과 유효이론

Instanton: **Classical gluon** dominating the non-perturbative QCD

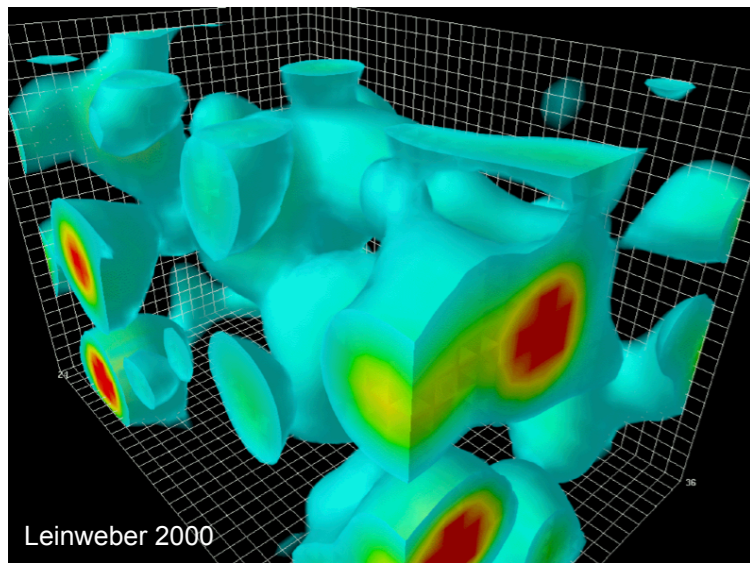

[QCD 진공]

모델링

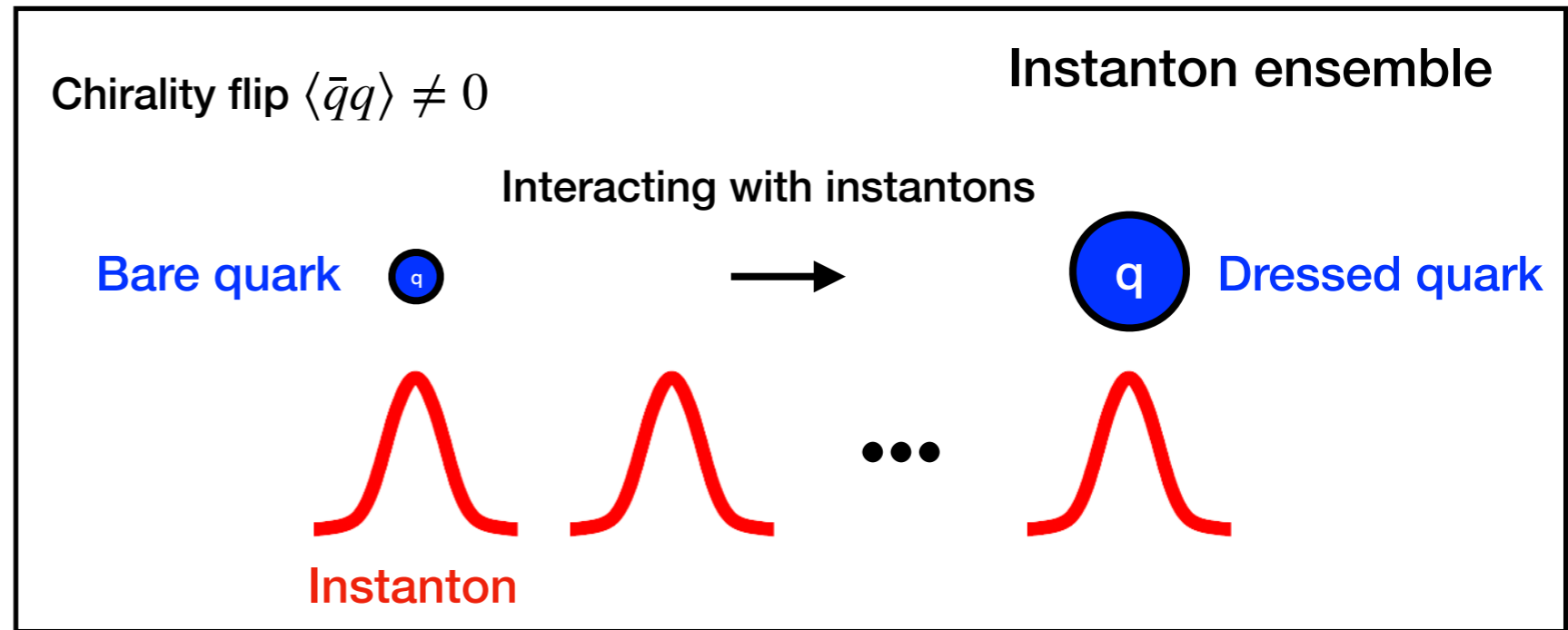

유효이론의 작용

$$S_{\text{eff}} = - \int d^4x \bar{\psi} [i\partial^\mu \gamma_\mu + iMU\gamma_5] \psi$$

Emergence of Goldstone boson (pion) field

Dressed quark mass

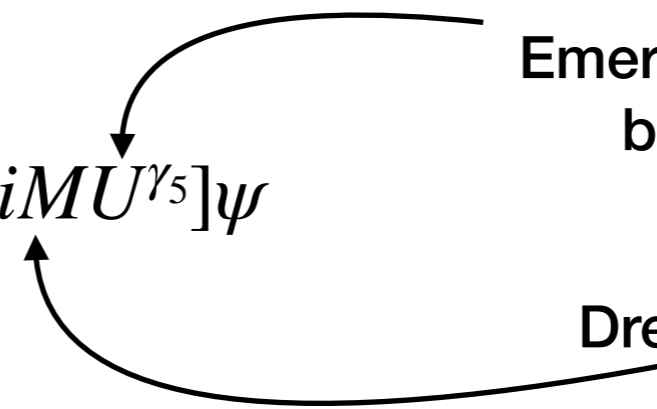

# QCD 인스턴톤 진공: 유효 연산자

양자색역학 에너지-운동량 텐서

$$\hat{T}_q^{\mu\nu} = \bar{\psi} \gamma^\mu i \nabla^\nu \tau \psi$$

$\nabla := \partial - iA$

유효 이론 에너지-운동량 텐서

$$(\hat{T}_{\text{eff}})_q^{\mu\nu} = \bar{\psi} \left( \gamma^\mu i \partial^\nu \tau + \frac{i}{4} F(MU^{\gamma 5}) \right) \psi$$



$\mu \approx 0.6 \text{ GeV}$

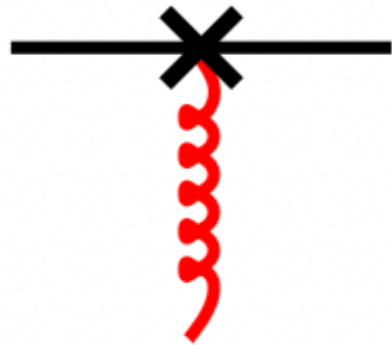

QCD gluon → Chiral interaction

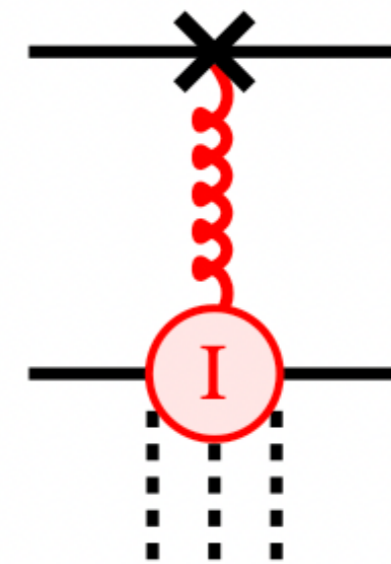

# 핵자 스핀의 분해

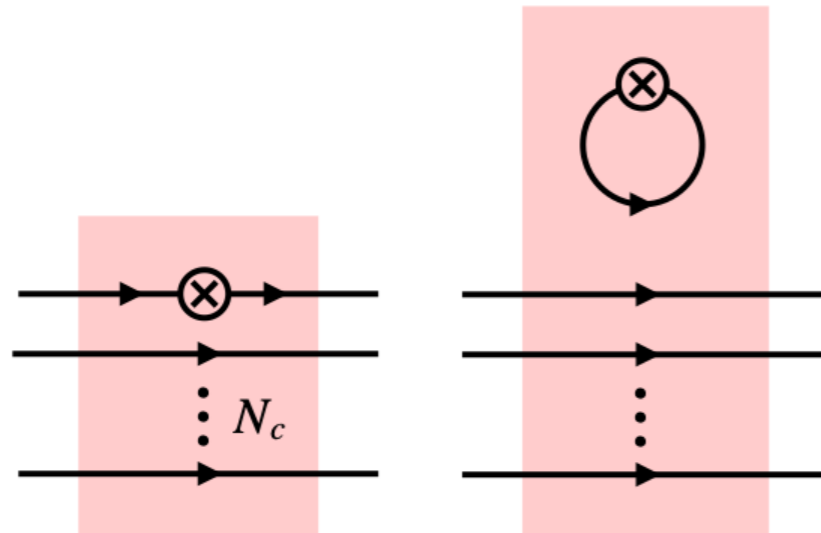

유효이론 기반 EMT 행렬요소 계산

Relativistic and field-theoretical approach

$$\langle N | (\hat{T}_{\text{eff}})^{\mu\nu}_q | N \rangle$$

핵자 스핀 분해 (Ji's sum rule)

$$J = S^q + L^q + J^g$$

Dominance of the **instanton-induced contribution**



$$L^{u-d}[\text{kin}] = -0.04 \ll L^{u-d}[\text{pot}] = -0.21$$

JYKim, Won, Weiss (2026) arXiv:2605.23125

**EIC 물리를 위한 이론 개발과 국제협력**

# Theoretical Development I: Nonperturbative Gluon Dynamics

## EIC 관측량을 여는 비섭동 글루온 이론 (2022 - 현재)

EMT 연산자를 유효 연산자로 변환

JYKim, Weiss PLB (2024)

JYKim, Weiss, in preparation

질량·스핀 분해로 양성자 내부 구조 규명

JYKim, Kim, Won, Weiss PRD (2024)

JYKim, Won, Weiss (2026) arXiv:2605.23125

JYKim, Lorce, Weiss Won, Kim, in preparation

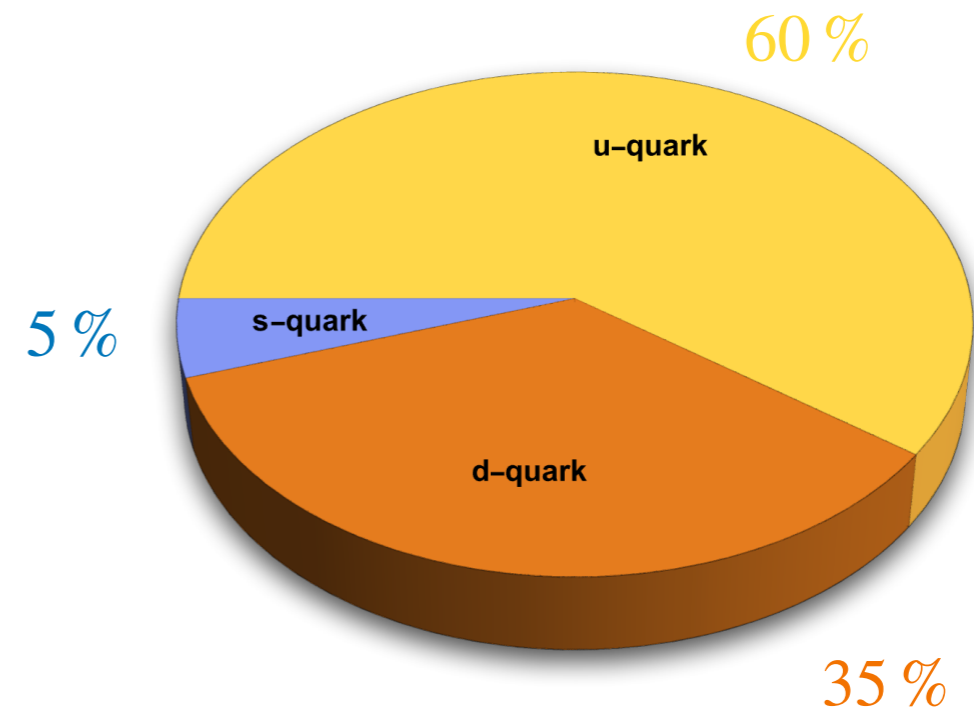
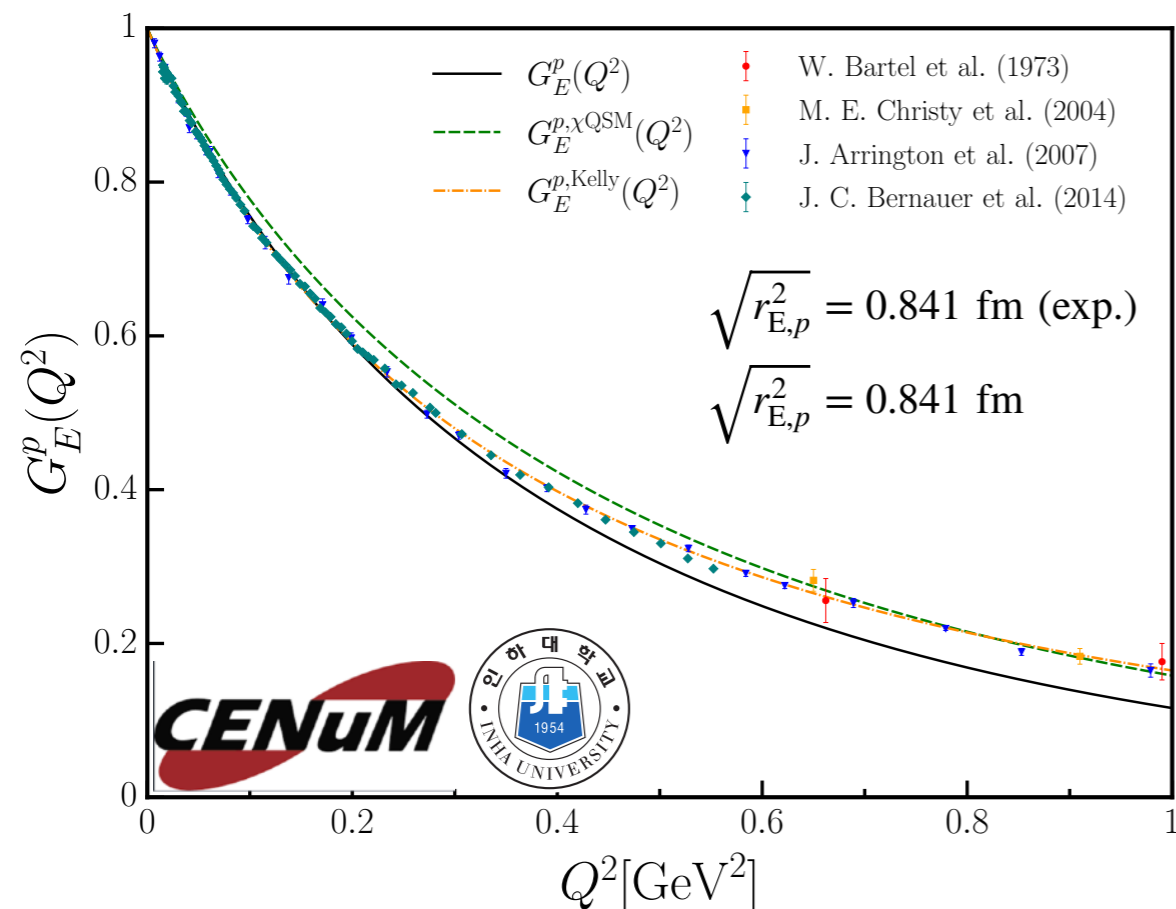

## 바리온 구조 속 비섭동 글루온 효과 (2018 - 2025)

인하대·CENuM(SRC) 주도하에 개발 완료

Choi, Kim PRD (2025)

비섭동 글루온 효과의 정량 예측 기반 마련

## EIC 관측량으로 확장 (2025 - 현재)

첫 적용 예시: 전자기 형태인자

HJLee, Choi, Kim (2026) arXiv:2605.25900

글루온 관측량까지 확장

# Theoretical Development II: New Physics

[EIC 핵심 관측량: **중력 형태 인자**]

$$\langle N | \hat{T}_{\mu\nu} | N \rangle = \bar{u} \left[ A(t) \frac{P_\mu P_\nu}{M_N} + J(t) \frac{iP_{\{\mu} \sigma_{\nu\} \rho} \Delta^\rho}{2M_N} + D(t) \frac{\Delta_\mu \Delta_\nu - g_{\mu\nu} \Delta^2}{4M_N} + \bar{c}(t) M_N g_{\mu\nu} \right] u,$$

새 물리:

압력/전단력

Polyakov & Weiss D-term (1999)

[첫 실험 관측]

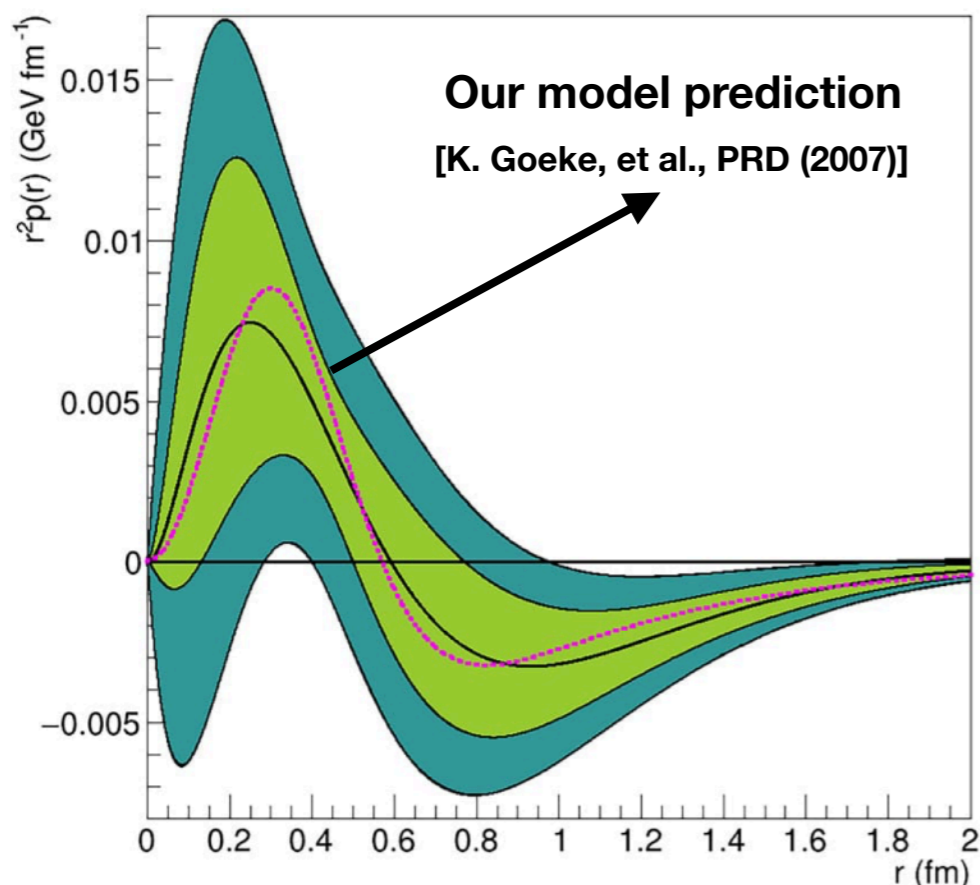

V.D. Burkert et al, *Nature* (2018)

- JLab에서 **에너지-운동량 텐서 최초 실험 관측**
- D-term과 양성자 내부 압력
- 기묘 쿼크 기여 측정 제안서, JLab 승인
- EIC에서 양성자 내부 압력·전단력 연구

Won, JYKim, Kim PRD (2023)

Won, JYKim, Kim JHEP (2024)

Studying the Strangeness *D*-Term  
in Hall C via Exclusive  $\phi$   
Electroproduction

Approved!

A Letter of Intent to Jefferson Lab PAC 52

# Theoretical Development II: New Physics

[EIC 핵심 관측량: **중력 형태 인자**]

$$\langle N | \hat{T}_{\mu\nu} | N \rangle = \bar{u} \left[ A(t) \frac{P_\mu P_\nu}{M_N} + J(t) \frac{iP_{\{\mu\sigma\nu\}\rho} \Delta^\rho}{2M_N} + D(t) \frac{\Delta_\mu \Delta_\nu - g_{\mu\nu} \Delta^2}{4M_N} + \bar{c}(t) M_N g_{\mu\nu} \right] u,$$

새 물리:

압력/전단력

Polyakov & Weiss D-term (1999)



Mariana Trench

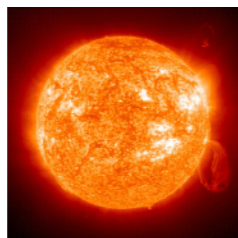

Core of the Sun



Core of a White Dwarf

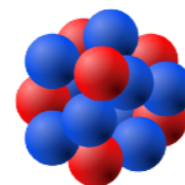

Nucleus

우리가 알고 있는 그 어떤 시스템보다 압력이 훨씬 크다.

\*1기압  $\approx 1 \times 10^5$  Pa

JYKim, Kim, Son, Polyakov, PRD (2020)

JYKim, Sun, EPJC (2020)

JYKim, Kim, PRD (2021)

Won, JYKim, Kim PRD (2022)

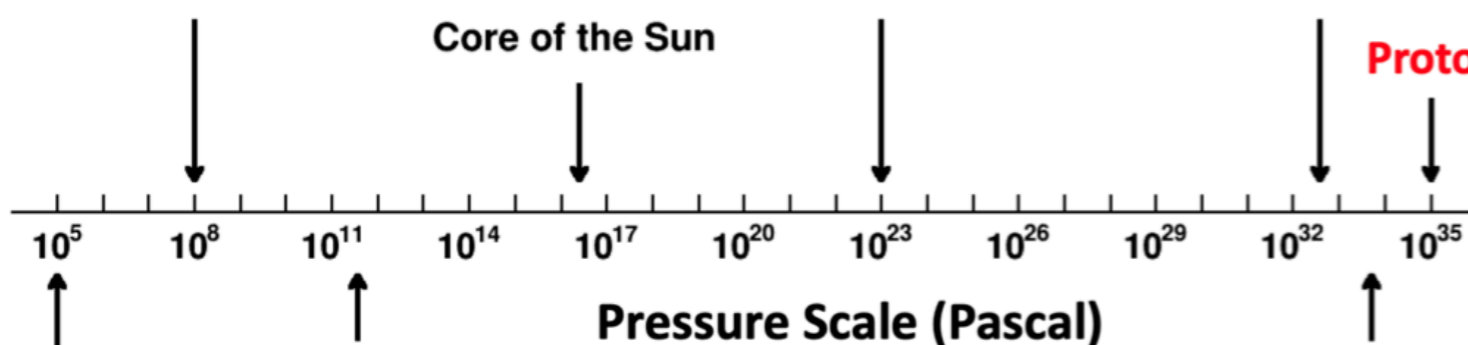

Atmosphere



Core of the Earth

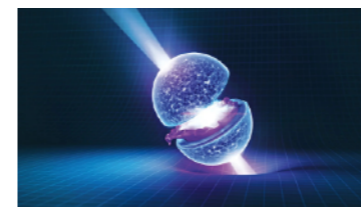

Neutron Star

# Theoretical Development II: New Physics

[EIC 핵심 관측량: **중력 형태 인자**]

$$\langle N | \hat{T}_{\mu\nu} | N \rangle = \bar{u} \left[ A(t) \frac{P_\mu P_\nu}{M_N} + J(t) \frac{iP_{\{\mu} \sigma_{\nu\} \rho} \Delta^\rho}{2M_N} + D(t) \frac{\Delta_\mu \Delta_\nu - g_{\mu\nu} \Delta^2}{4M_N} + \bar{c}(t) M_N g_{\mu\nu} \right] u,$$

새 물리:

Polyakov, Son, JHEP (2022)  
 Won, JYKim, Kim, PLB (2024)  
 JYKim, Kim, PRD (2025)

$$\partial_\mu \hat{T}_q^{\mu\nu} = -\partial_\mu \hat{T}_g^{\mu\nu} = \hat{f}^\nu$$

쿼크와 글루온 사이의 힘

Stretching force

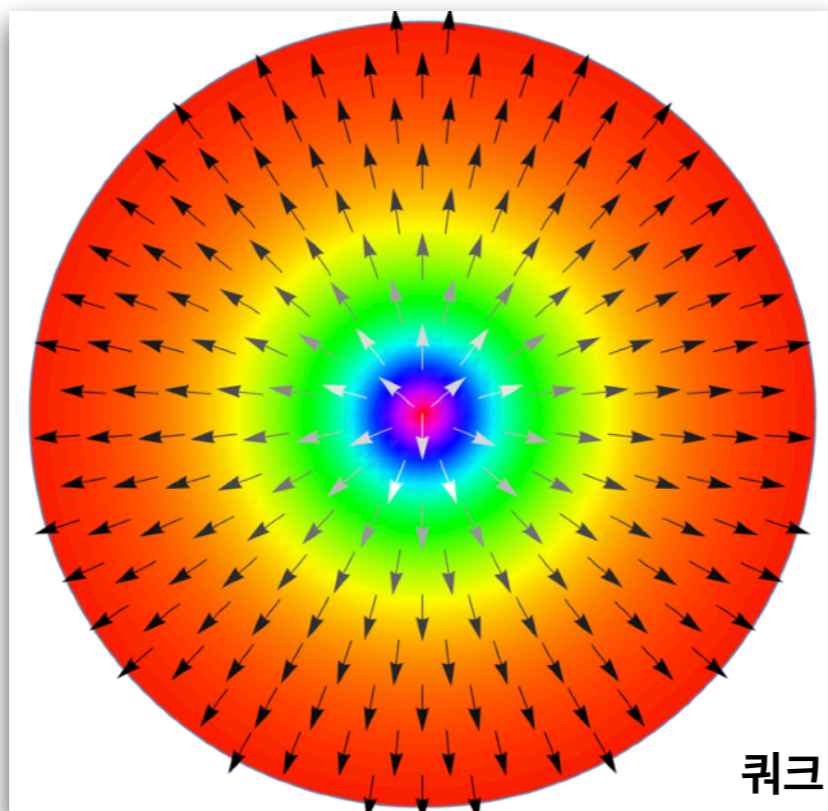

Squeezing force

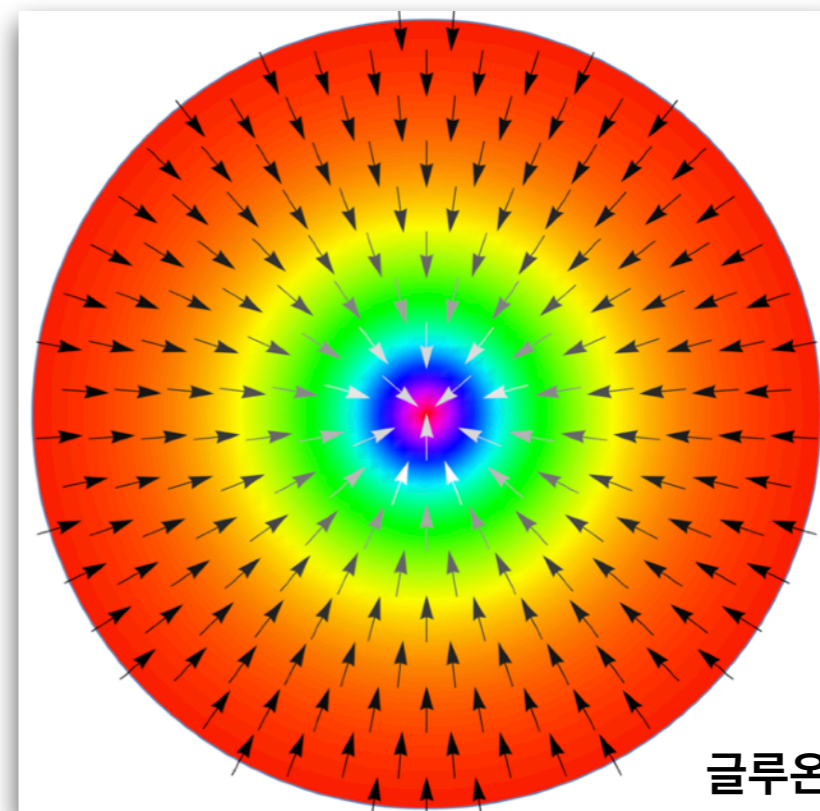

대략  $10,000 N \approx 1,000 \text{ kgf}$

# Theoretical Development III: 3D tomography of the nucleon

## 3차원 토모그래피 (2024 - 현재)

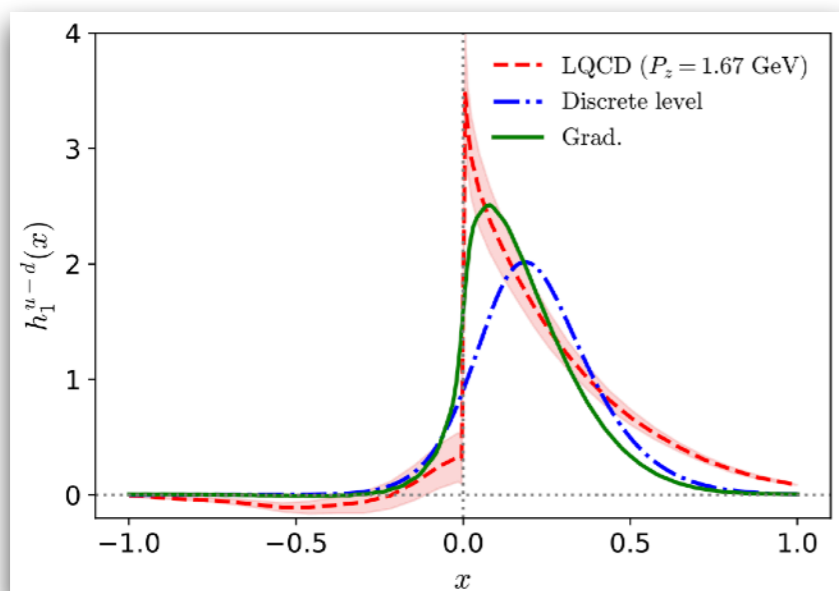

유효이론에서 GPD sum rule과 polynomiality 증명

GPD 간 계층구조와 제약조건 도출

JYKim, PRD (2025)

JYKim, C.Weiss, PRD (2025)

유효이론 기반 GPD 수치 예측

JYKim, C.Weiss, in preparation



## 전이 GPD (2022 - 현재)

첫 실험 논문 (JLab); EIC, J-PARC에서 추출 가능

S. Diehl et al, PRL (2023)

선구적 연구를 주도하며 이론 기반을 구축하였다.

JYKim, PLB (2022)

JYK, Won, Goity, Weiss, PLB (2023)

JYK, Semenov, Weiss et al, PRD (2025)

JYK, Weiss, PLB (2025)

APCTP-ECT\* transition GPD Workshop / White paper

S. Diehl et al, EPJA (2025)

# US Collaboration on EIC



U.S. DEPARTMENT  
of ENERGY



Supported by DOE topical collaboration program (DE-SC0023646)

## Involved Institutions

JLab, Argonne Lab, LBNL, Maryland, Temple, Kentucky, Penn State, MIT, Duke, William & Mary, Stony Brook, Connecticut, Hampton, Washington ...

## Contributions

[JYK, PRD (2023)]

[JYK, Goity, Won, Weiss, PLB (2023)]

[JYK, Weiss, PLB (2024)]

[JYK, Kim, Won, Weiss, PRD (2024)]

[JYK, Semenov, Won, Son, Weiss, PRD (2025)] ...

## Quark-gluon tomography (QGT) topical collaboration

<https://qgtcollab.github.io/>

“3D quark-gluon structure of hadrons: mass, spin, and tomography.”

Support measurements at EIC, JLab, HERMES, and COMPASS.



QGT All-Hands Meeting

국내 이론 그룹 간 교류 확대와 시너지 창출

# International Network [co-authors are marked in blue.]

## China

Beijing, Inst. High Energy Phys.  
[ YB Dong, DY Fu ]  
Zhengzhou U. [ Qin-Tao Song ]

## France

Ec. Polytech. [ C. Lorcé, H.-Y. Won,  
R. Boussarie, C. Marquet, B. Pire ]

## Germany

Ruhr U., Bochum [ M. V. Polyakov<sup>†</sup>, E. Epelbaum, U. Wuppertal [ P. Kroll ]  
J.Y. Panteleeva, H. Alharazin, BD Sun ]  
Mainz U. [ M. Vanderhaeghen, V. Pascalutsa ]



## Japan

Nishina Ctr.,  
RIKEN and JAEA  
[ M. Oka ]  
Osaka U. [ T. Hyodo ]  
Tohoku U. and  
Nishina Ctr.,  
RIKEN [ E. Hiyama ]

## Russia

St. Petersburg,  
INP [ K. M. Semenov-Tian-Shansky ]

## Poland

Jagiellonian U.  
[ M. Praszalowicz ]

## Italy

Pavia [ B. Pasquini ]

## Taiwan

Taiwan, Inst. Phys.  
[ W.C. Chang ]

## USA

JLab [ C. Weiss, Jianwei Qiu, Volker Burkert, L. Elouadrhiri,... ]  
Hampton U. [ J. L. Goity ]  
SUNY [ I. Zahed, E. Shuryak ]  
BNL [ Y. Hatta ]

## Connecticut U. [ P. Schweitzer, K. S. Joo, S. Diehl ]

Virginia Tech [ Marie Boer, T. Kemal ]  
Virginia U. [ S. Liuti ]  
George Washington U. [ I. Strakovsky ]  
NC State U. [ C. R. Ji ]  
+ QGT collaborators

# Summary

- EIC는 양성자 내부의 질량과 스핀 구조를 새롭게 검증할 실험이다.
- 그 중심에는 **GPD와 중력 형태 인자**가 있다.
- 핵심 난제는 **비섭동 글루온**이다.
- 질량·스핀·압력 분해의 열쇠는 글루온 동역학에 있다.
- **EIC는 양성자 속 글루온 동역학을 정밀하게 드러낼 실험이다.**
- **비섭동 글루온의 이해를 심화하기 위한 연구를 수행 중이며, 앞으로도 지속적으로 발전시켜 나가고자 한다.**

**Thank you very much!**

# 양성자의 질량과 스핀 정의와 연구 (1960s)

$$\hat{T}^{\mu\nu} = \frac{2}{\sqrt{-g}} \frac{\delta S_{\text{QCD}}}{\delta g_{\mu\nu}}$$

중력은 물질과 **에너지-운동량 텐서**를 통해서 결합

**질량과 스핀**의 정보를 포함

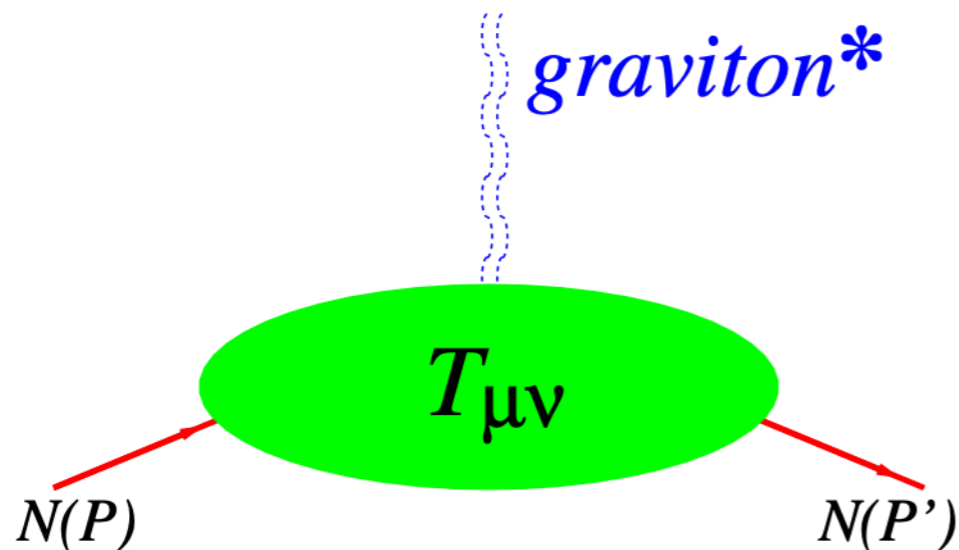

## 양성자의 질량과 스핀의 연구

중력자와의 상호작용이 매우 약해 직접 측정이 어려움

쿼크와 글루온 성분으로의 분해가 어려움

$$\langle N | \hat{T}^{\mu\nu} | N \rangle$$

[Kobzarev & Okun (1962), Pagels (1966)]